

stepping stones for stags



Females rarely fly but emit chemicals to attract males



Eggs are laid underground near dead wood



Larvae live underground for up to 7 years eating dead wood



Adult beetles only live for around 6 weeks

Stag beetle facts

- Britain's largest native terrestrial beetle
- The male's antler-like mandibles (jaws) are used for fighting with each other
- Adults can grow to 70mm
- Adults rarely feed, but do like nectar and juices from sweet fruit
- **They are harmless**

Why stag beetles need your help

A major problem facing not only our native stag beetles but many other species that also rely on rotting wood is that there is much less deadwood habitat for them than there used to be. We would like you to help us by continually replenishing dead wood where stag beetles are known to exist to ensure that these populations survive.

Another major problem is that stag beetle populations are becoming isolated, so we would like you to help, where possible, by creating log pyramid *stepping stones for stags* so that they can colonise new areas more easily. Stag beetles do not move very far from where they emerge. Although males can fly for up to 500m, most females travel no more than 20m. Thus it would help the beetles if log pyramid stepping stones could be built, starting close by a colony that you know, so that we ensure that there is a good supply of suitable dead wood nearby for females to lay their eggs in.

Let us know

Once you've created your log pyramid please take a photo of it and email it to stagbeetle@ptes.org or visit www.ptes.org/stagbeetles. An ID guide of other creatures that may use your log pile can be downloaded from our website.

What you can do

Create a log pyramid in your garden for beetles and other wildlife, too.

- Use wood from any broadleaved tree, but especially oak, beech or fruit trees such as apple or pear as these support the richest insect communities.
- Site the logs in partial shade, if possible, to prevent them from drying out.
- Fresh logs with the bark attached provide better and longer-lasting habitats.
- The logs should be at least the thickness of an adult's arm.
- Partially bury the logs vertically in the soil so that they retain moisture and increase the numbers of visiting insects. Stag beetles lay their eggs near decaying wood. Buried dead wood ensures a good food supply for their larvae.
- Avoid making log piles too high, or the timber will dry out.
- Allowing plants to grow over the log pyramid both retains moisture and provides shade for the stag beetles.

Log pyramids can be built at any time of year. It will take a while for the wood to rot down sufficiently to be in the right condition for stag beetle larvae, and many other animals, to feed on.

Different types of log pyramids

Large log pyramid suitable for parks and large gardens (see photo)

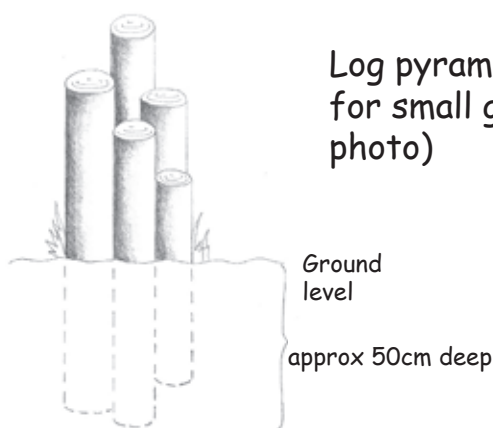
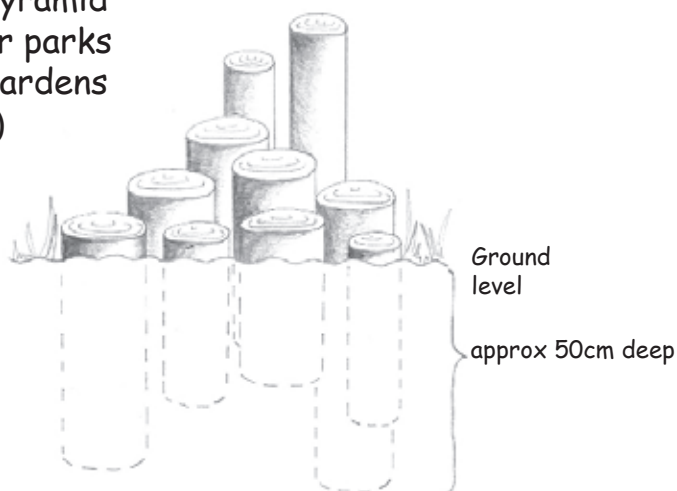

Log pyramid suitable for small gardens (see photo)

or, if space is limited...

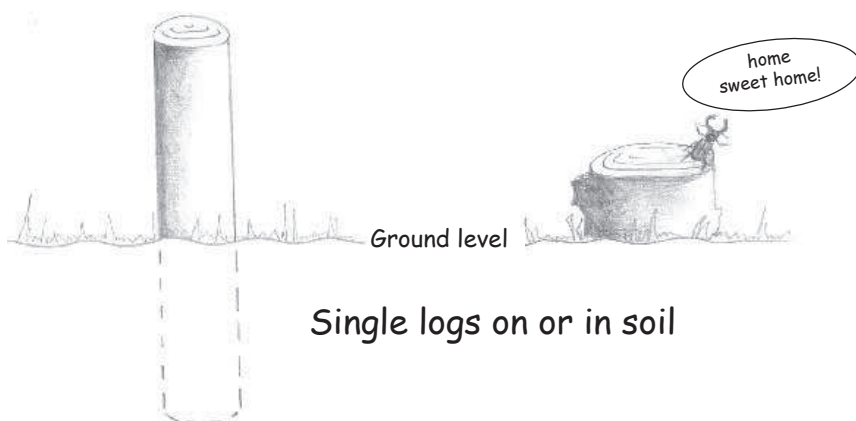

Single logs on or in soil

Other do's and don'ts in your garden or park:

- Leave tree stumps in situ if possible; they can become garden features with plants growing over them.
- Avoid using polythene sheeting covered with bark chippings to control weeds. Newly emerging adult beetles can get trapped beneath it in spring and die.
- If you find larvae in the base of rotten timber posts, for example, and need to move them, dig a hole elsewhere in your garden and put them in, together with some of the rotting wood from their original site. Cover loosely with soil.
- Try to leave some quiet, undisturbed areas in your garden. This will benefit other wildlife, too.
- Try not to use insecticides.
- Keep cats away from beetle habitat if you can.
- Keep a lid on your water butts, as stag beetles are known to fall in and drown.
- Share this leaflet with your gardening friends.



for more information please contact:

PTES
15 Cloisters House
8 Battersea Park Road
London
SW8 4BG

enquiries@ptes.org
www.ptes.org

020 7498 4533

or:
for free educational resources
please visit www.ptes.org/education

registered charity no. 274206